

Operating instructions

VISATEC

SOLO 400/800/1600/ 3200 B

www.visatec.com

Before use

Please read all the information contained in these operating instructions carefully. They contain important details on the use, safety and maintenance of the appliance. Keep these operating instructions in a safe place and pass them on to further users if necessary.

Observe the safety instructions.

Contents	page
Safety information	2
Controls and displays	3
1. SOLO 400 B / SOLO 800 B / 1600 B / SOLO 3200 B	5
2. Application	5
3. Commissioning	5
4. Flash tube/Protecting glass	6
5. Modelling lamp	6
6. Fuse	7
7. Heating/temperature monitor	7
8. Afterglow blackout	7
9. Battery operation	8
10. Mounting	8
11. Changing of reflectors	8
12. Mounting of barn doors	9
13. Umbrella bracket	9
14. Flash release	9
15. Service and repair	9
16. Technical data	10
17. Order numbers for diverse spare parts/accessories	11

Safety information

Attention: Read before startup

- Prior to replacing the fuse, light lamp or flash tube, discharge the unit and disconnect from power. Allow the unit to cool off for 10 minutes before replacing the lamp or flash tube.
- Only those types of fuses indicated on the fuse label may be used. This is particularly important for fusing the halogen lamp which may burst if the wrong fuse is used.
- Only sand-filled fuses may be used. Sand-filled fuses can be identified by the opaque body of the fuse.
- The devices are designed for use in dry rooms. Protect them against splash water and against excessive exposure to dust.
- The devices are not suitable for use in an environment with risks of explosion.
- The accessories mounted to the unit may heat up to high temperatures under specific conditions. Handle with care!
- To protect against the effects of radiated heat, the unit must not be pointed at flammable surfaces from less than 1 meter away.
- Do not block the cooling louvers on the unit.
- Flash light contains, similar to sunlight, a specific portion of UV light. The undesirable side effects on skin and eyes are considerably reduced by using flash tubes with UV coating. Without these or other protective filters, use extreme care when shooting.
- Even when disconnected from power, dangerous voltages may remain within the interior of the device. For this reason, devices should be opened by our VISATEC repair service.
- For safety reasons, operate a lamp (resp. a unit) only with the mounted protecting glass. The protecting glass should not be damaged, to guarantee a perfect functioning of the unit.
- The unit may only be used for professional photography and must only be operated by trained personnel.

Controls and displays

1. Flash release key
2. Jack for synchronous cable
3. Flash ready control lamp
4. Connection socket for mains cable
5. Fuse
6. Switch for modelling light (proportional/full)
7. Switch for modelling light (on/off)
8. Main switch (on/off)
9. Slave cell (on/off)
10. Rotary switch for power control
11. Switch for dim function (flash release control)

Front panel to SOLO

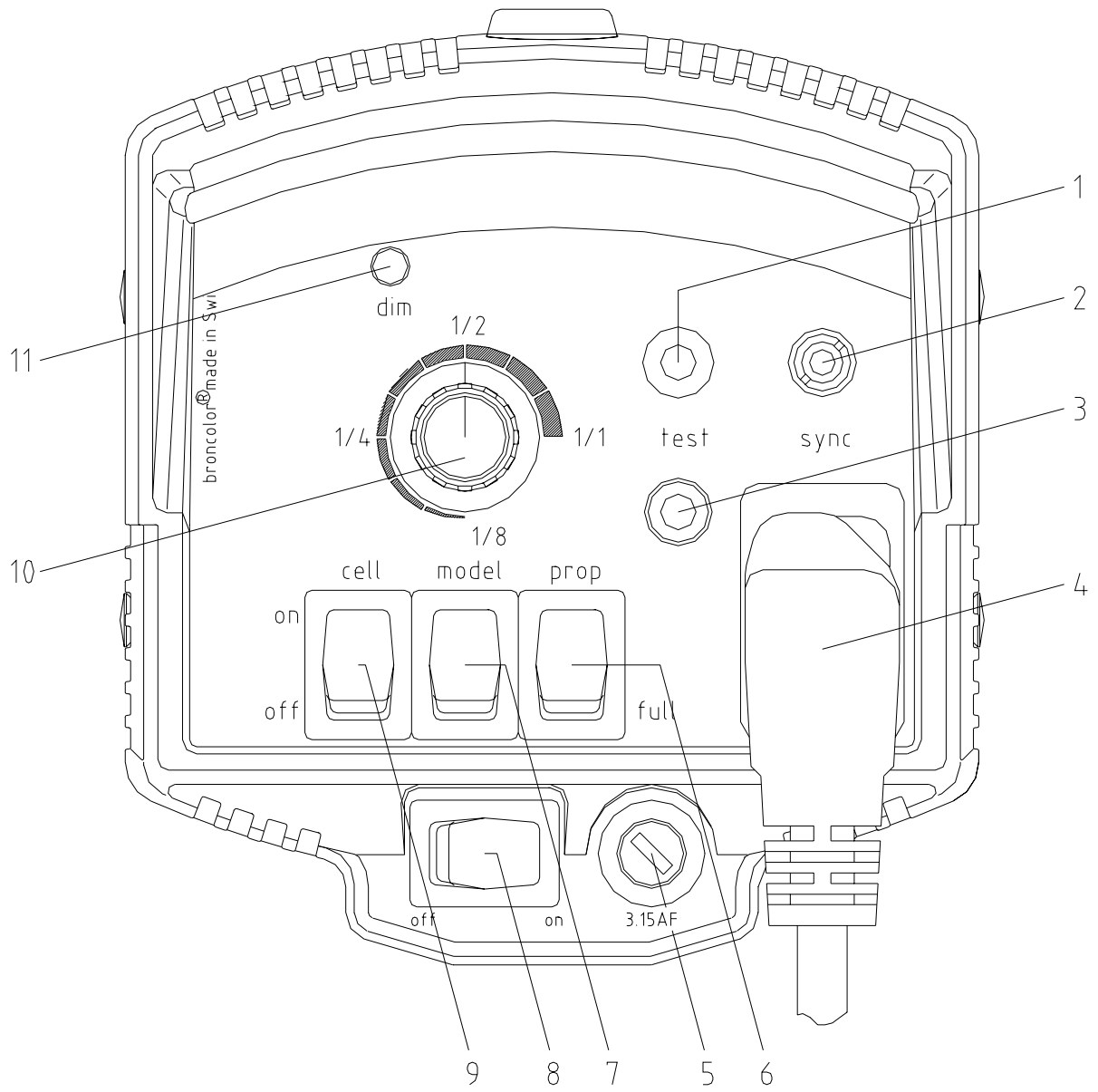

1. SOLO 400 B / SOLO 800 B / 1600 B / SOLO 3200 B

We are delighted that you have chosen the high quality product VISATEC SOLO. With proper care it will render you many years of good service.

2. Application

This mains supplied studio flash unit is designed for professional photography only. In countries with earthed mains systems, use a three-wire extension cable whenever needed.

3. Commssioning

- 3.1 Remove grey plastic hood by rotating. Insert desired reflector and protecting glass and rotate in any direction.
- 3.2 Please check that the mains supply corresponds to the information on the label of the unit. Connect unit to earthed power.
- 3.3 Switch on main switch (8) and modelling light (7).
- 3.4 The modelling light can be switched off or on during charging (dim function) by pushing in switch (11) with a small screwdriver. This option allows the photographer to confirm visually that all the VISATEC SOLO units have fired.
- 3.5 Set intended flash output via control knob (10).
- 3.6 Green control lamp (3) will illuminate: this is how the units show that it is ready
- 3.7 Release test flash by pressing key (1).
- 3.8 Switch photocell (9) on or off, depending on the shot-situation.
- 3.9 If needed, plug in synchronous cable (2).

4. Flash tube/Protecting glass

The flash tube or the protecting glass is coated to achieve an optimal colour temperature. For your security, only original flash tubes should be used. For safety reasons, never operate a unit without the protecting glass in place.

If you need the compact unit SOLO 800 B for longer flash sequences, we propose the use of the flash tube to SOLO 1600 B.

4.1 Changing of the flash tube:

1. To replace it, fire a flash, disconnect unit from power, and allow to discharge and cool off for ten minutes (to ensure that the flash capacitor has discharged).
2. Remove the protecting glass.
3. First pull out the triggering cable and then the flash tube (do not touch with bare hands).
4. Insert the new flash tube.
5. Insert the triggering cable.
6. Replace the protecting glass.
7. Plug in the unit, now it is ready for use.

5. Modelling light

The units are equipped with a very bright 150W halogen modelling light. The halogen lamp can be plugged in, when exchanging, beware of touching the lamp with bare hands.

Please note, that you must pull out the flash tube before exchanging the modelling lamp.

In order to meet the european security standard, the modelling lights which are offered by the manufacturer must be used.

6. Fuse

The fuse (5) is located on the rear of the unit. Sand-filled fuses with a value 3.15 AF may only be used (sand-filled fuses can be identified by their opaque fuse container). Using an incorrect fuse is dangerous: it may cause the halogen lamp to burst. The correct fuse is therefore included with each original VISATEC replacement lamp.

7. Heating/temperature monitor

In the proximity of the halogen lamp, the unit, depending on adapters used, can acquire high temperatures. For this reason, we recommend touching the unit on the handle behind or on the stand adapter only. Due to the intense heat radiation when a modelling light is in operation, keep the unit at a minimum distance of 1 m from flammable surfaces.

The units SOLO 800 B / 1600 B / 3200 B contain a temperature sensor which protects the electronic circuitry from overload during long flash sequences. If the safety system is activated, the modelling light goes out and charging is blocked. The ready indicator light changes to red until the unit has cooled off. The fan will continue to operate to promote faster cooling. Using the SOLO 400 B, only a maximum of 120 flashes are possible within 1 hour.

8. Afterglow blackout

The units SOLO 800 B / 1600 B / 3200 B are equipped with an automatic afterglow blackout. If the flash tube begins to exhibit afterglow (at the end of its service life, for example), this blackout blocks further charging to prevent any additional damage. The ready indicator light also glows continuously red to indicate this condition. To cancel the blackout, switch the unit off and then on again.

9. **Battery operation**

If no mains power is available, use the 12-volt car battery converter to load (only for 220V units).

The modelling light cannot be used on this mode (excessive load on battery).

- Switch off modelling light and pull it out.
- Connect converter to the 12-volt car battery with the + and - connector clamps.
- Connect unit to converter; Switch on converter and unit.
- After flash work, switch off converter during pauses. Charge battery if needed by allowing the car engine to run.
- One SOLO compact unit can be connected to the converter (220V). A fully charged battery results in the following charging times, respectively flash discharges:

SOLO 400 B	120 flashes at 130 J	3.5s
SOLO 800 B	100 flashes at 300 J	5s
SOLO 1600 B	100 flashes at 600 J	7s
SOLO 3200 B	50 flashes at 1200J	12s

10. **Mounting**

The stand adapter is located below the housing. The adapter will accept standard broncolor® bolts and Manfrotto® pins.

Make sure the lamp is firmly attached to the stand before operating. The click-stops of the locking handle can be adjusted by pulling it out.

A locking pin is screwed into the lower part of the stand adapter so it can be hung from a broncolor® bolt; this is not required for stand mounting, and must be removed. A safety cable must be installed whenever the lamp head is suspended.

11. **Changing of reflectors**

Reflectors and accessories are provided with an adapter which is to be fixed to the bayonet mounting with a slight turn.

12. Mounting of barn doors

The barn doors are inserted on the mounting supports of the reflector.

13. Umbrella bracket

The umbrella reflector (art. no. 53.457.00) is used in conjunction with umbrella diffusers and reflectors. The umbrella handle is inserted into the special holder in the stand adapter.

14. Flash release

The release is possible via sync cable, photocell or with manual release button.

The units are fitted with a synchronous circuit with low working voltage to protect the camera contact. This synchronous contact may not be switched parallel with outside brands since the latter work with high synchronous voltage.

When releasing by the photocell make sure that the receiver cell of the unit is not blocked by obstacles.

As the photocell is also sensitive in the infrared range, the unit can be triggered, wirelessly, via a small flash unit on the camera fitted with an IR-permeable filter.

15. Service/repair

Your VISATEC compact unit is a precision device which will work for many years without malfunctions if you take proper care of it. If malfunctions do arise, please do not attempt to open the unit so as to repair it yourself. Even when the unit is shut off, dangerous voltages may remain within the interior of the device. Leave service and repairs to our VISATEC repair service.

16. Technical data

	SOLO 400 B	SOLO 800 B	SOLO 1600 B	SOLO 3200 B
F-stop at 1 m (ISO 100, standard reflector)	32	45	64	90
Flash duration (t 0.5)	1/1200s	1/800s	1/600s	1/900s
Charging time (to 100% of selected energy)	0.25s-1.1s	0.6-1.4s	0.7-1.9s	0.6-2.2s
Ready indicator	Visual at 100% of selected energy			
Control range of flash energy	Over 3 stops	Over 3 stops	Over 3 stops	Over 4 stops
Modelling light	Halogen 150W	Halogen 150W	Halogen 150W	Halogen 150W
Flash release	Sync cable, infrared-sensitive* photocell (can be switched off), manual test button			
Reflector mount	Patented interlocking bayonet			
Stabilized flash voltage	+/- 1%	+/- 1%	+/- 1%	+/- 1%
Power requirements	200-240V, 50 Hz:6A 110-120V, 60 Hz:6A	110-120V, 60 Hz: 10A 220-240V, 50Hz: 6A 100V, 50 Hz: 10A	200-240 V, 50 Hz: 10A 110-120 V, 60 Hz: 10A 100 V, 50 Hz: 16A	200-240 V, 50 Hz: 10A 110-120 V, 60 Hz: 16A 100 V, 50 Hz: 16A
Norms	EC standards, 73/23, UL 122			
Dimensions (not including handle)	120x190x340 mm	120x195x410 mm	120x195x410 mm	120x195x495 mm
Weight	2,3 kg / 5,1 lbs.	2,4 kg	2,6 kg	4,3 kg

* The infrared-sensitive photocell of the SOLO units reacts to a small amateur flash with a dark red filter placed in front of it.

Subject to change in the interest of technical development.

17. Order numbers for diverse spare parts/accessories

Flash tube, coated for SOLO 800 B	art.no. 54.300.00
Flash tube, coated for SOLO 1600 B	art. no. 54.301.00
Flash tube, clear for SOLO 3200 B	art. no. 54.302.00
Flash tube, coated for SOLO 400 B	art. no. 54.303.00
Halogen modelling lamp (150W/120V)	art. no. 54.251.XX
Halogen modelling lamp (150W/230V)	art. no. 54.252.XX
Protecting glass, clear	art. no. 54.400.59
Protecting glass coated for SOLO 3200 B	art. no. 54.401.00
Fuse 3.15 AF	art. no. 37137.00
Protection cap for transport, grey	art. no. Z6098.00
Mains cable CH 200-240V	art. no. 39084.00
Mains cable USA 100-120V	art. no. 39085.00
Mains cable Europe 200-240V	art. no. 39086.00
12 V battery converter 220V	art. no. 36.450.10
Sync cable	art. no. 54.104.00

CE

Printed in Switzerland 1.1.03

Bron Elektronik AG
CH-4123 Allschwil
Schweiz (Switzerland)